

8 7 6 5 4 3 2 1

D  
C  
B  
A

D  
C  
B  
A

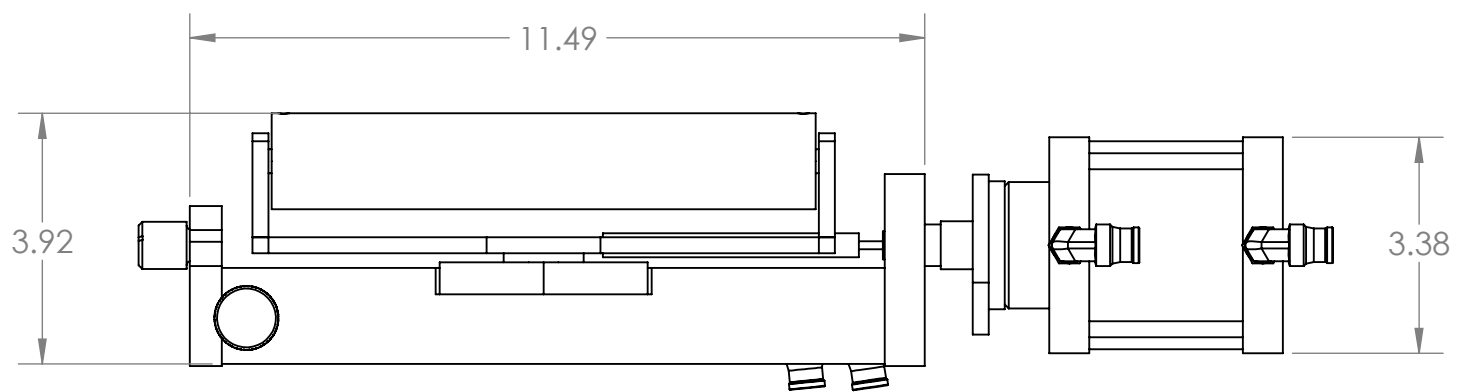
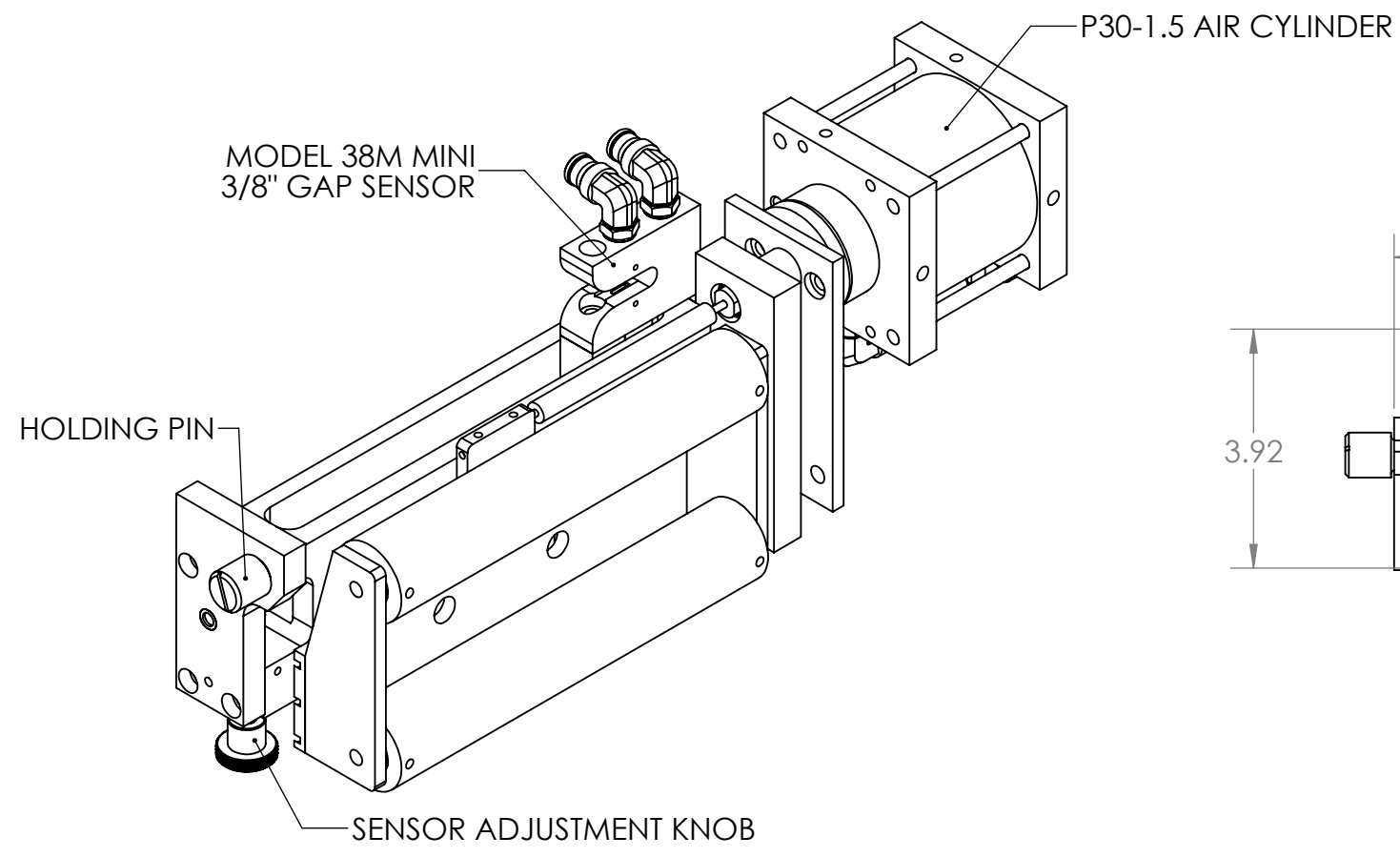
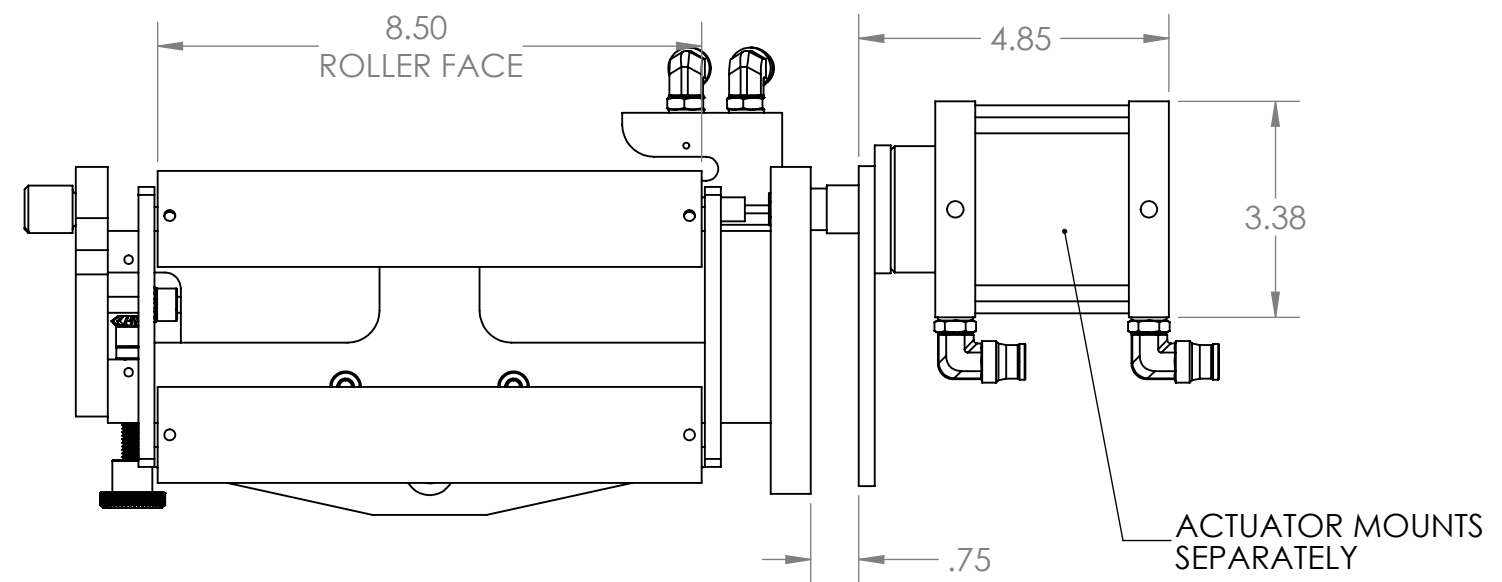
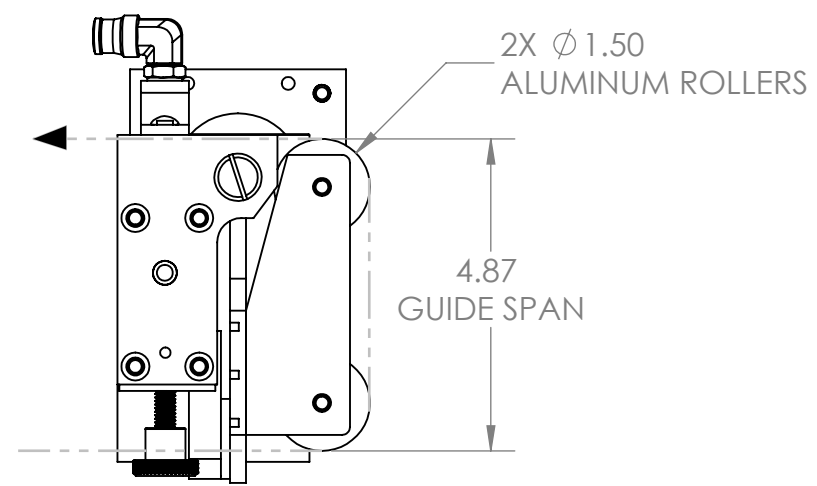

**COAST CONTROLS, INC.**  
 7500 COMMERCE CT.  
 SARASOTA, FL34243  
[www.coastcontrols.com](http://www.coastcontrols.com)  
 941.355.7555 | 941.359.2321

	NAME	DATE
DRAWN	APK	8/15/2023
CHECKED		
ENG APPR.		
MFG APPR.		
Q.A.		
PAGE:	3-4263	
QUOTE:	Q2307-24	

TITLE: DISPLACEMENT GUIDE DIMENSIONS (MARK ANDY 830 7" WEB)		
SIZE	DWG. NO.	REV
<b>B</b>	MDG3-0905-MA	-
SCALE: 1:3	WEIGHT: 12.54	SHEET 1 OF 1

**PROJECTION IS THIRD ANGLE**

UNSPECIFIED TOLERANCES

	FRACTIONS $\pm$ 1/32		ANGLES $\pm$ 1 DEG	
INCH	.X $\pm$ .030	.XX $\pm$ .015	.XXX $\pm$ .005	.XXXX $\pm$ .0005
MM	.X $\pm$ 1.0	.XX $\pm$ .50	.XXX $\pm$ .25	

DO NOT SCALE DRAWING

**PROPRIETARY AND CONFIDENTIAL**

THE INFORMATION CONTAINED IN THIS DRAWING IS THE SOLE PROPERTY OF COAST CONTROLS, INC. ANY REPRODUCTION IN PART OR AS A WHOLE WITHOUT THE WRITTEN PERMISSION OF COAST CONTROLS, INC. IS PROHIBITED.

DRAWINGS FOR APPROVAL NEED TO BE SIGNED, DATED AND RETURNED TO COAST CONTROLS, INC. BEFORE ANY MANUFACTURING CAN BEGIN.

APPROVED SIGNATURE X \_\_\_\_\_ DATE \_\_\_\_\_

8 7 6 5 4 3 2 1